

# data M

Your Partner in  
the Roll Forming  
Industry

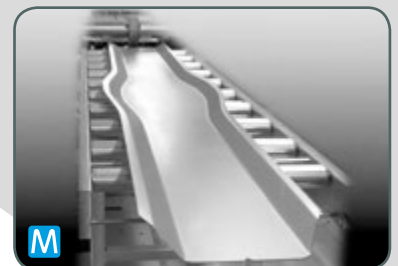
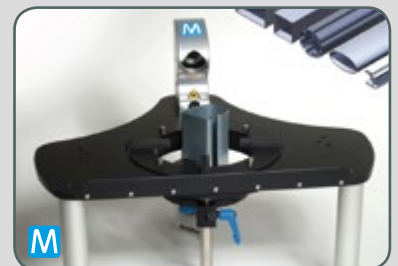
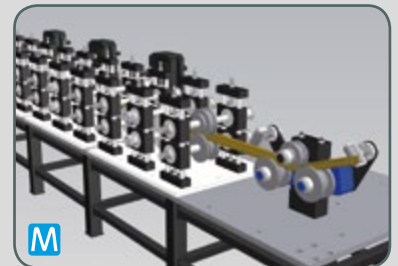
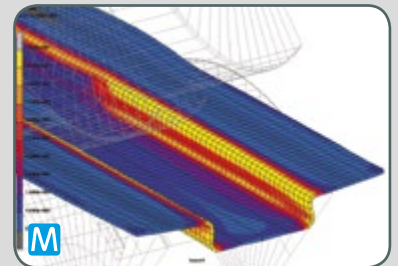
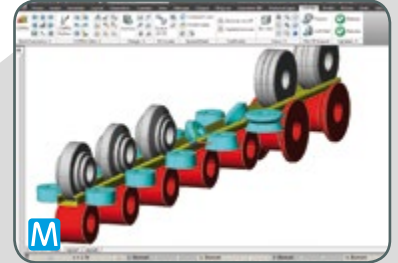
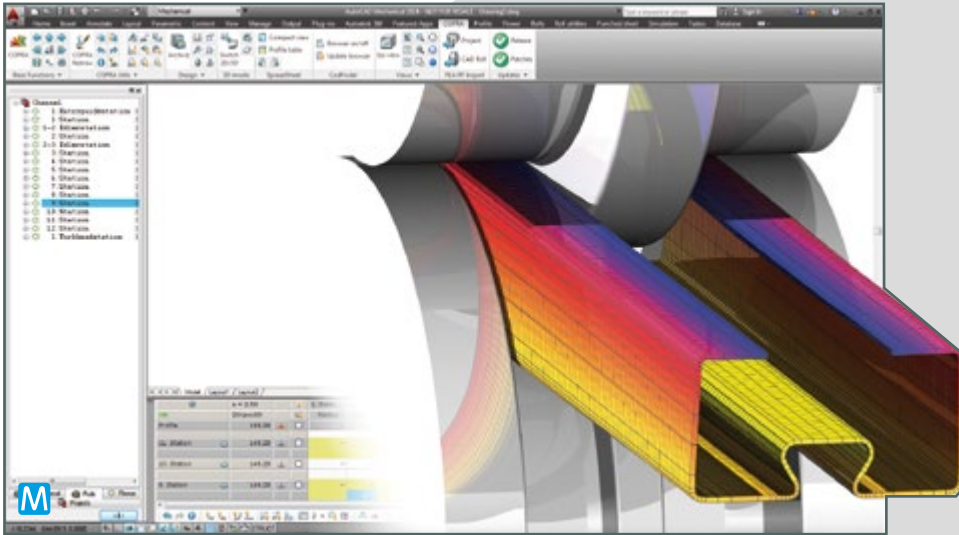

**data M**  
Sheet Metal  
Solutions

## COPRA® RF and COPRA® FEA RF:

After 30 years using another CAD system, what were the key reasons in the decision by a major metal forming company to switch its operations to COPRA® RF and COPRA® FEA RF?

### PARAMETRICS

- | Straight-forward modification of profile cross-sections
- | Automatic updating of entire flower pattern
- | Easier and accelerated design process

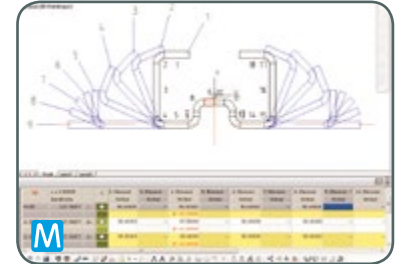

### 3D OPTION

- | 3D presentation of rolls and profiles to enable collision control
- | Easy changeover between design mode and 3D viewing
- | Fast, simple and efficient roll tool development

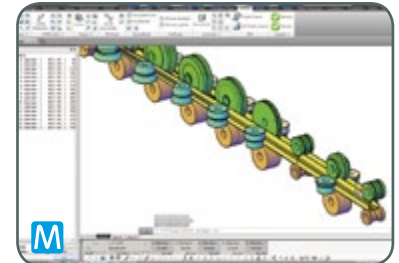

### ROLL MANAGEMENT

- | Archiving of whole tool sets in database
- | Integrated standard rolls management by combined rolls manager
- | Easiest and speedy tracing and re-use of rolls
- | Roll and material billing management



### FEA SIMULATION

- | Entire FEA models created in seconds
- | No time-consuming preprocessing or awkward postprocessing
- | Roll-form-optimized remeshing during FEA calculation
- | Automatic transfer of punch hole data into FEA model

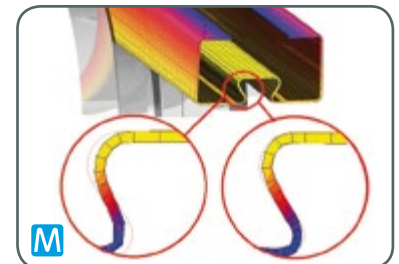

### PRE, POST AND INLINE OPERATIONS

Simulation of subsequent work steps:

- | Punching
- | Inline bending
- | Winding
- | High-frequency welding



## Quality Management with COPRA® ProfileScan

Completing the work process of roll profile development, data M developed a profile scanner and a roll scanner.

- | High-precision laser inspection
- | Significant reduction of time to scan
- | Complete integration into COPRA® RF and COPRA® FEA RF
- | Simple tools to define jobs and tolerances
- | Automatic scanning report
- | Ideal for quality management
- | Optional in-line scanners (sensor rings) or customized systems

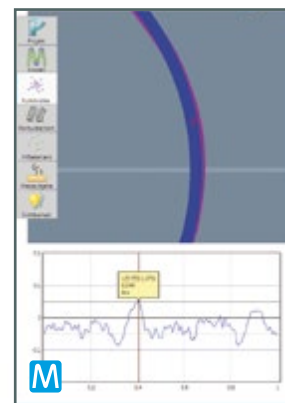
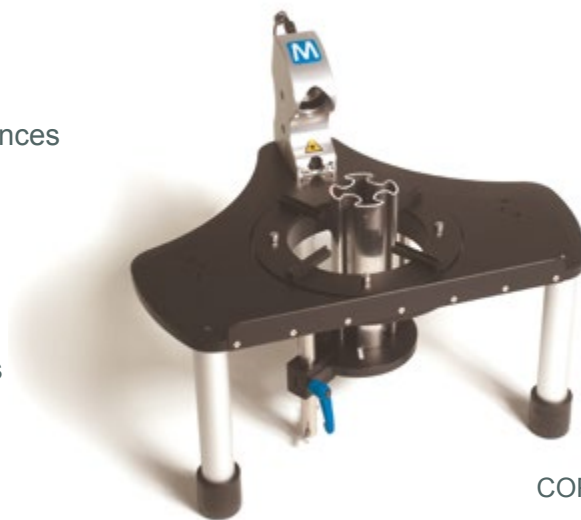

COPRA® ProfileScan Desktop

## Quality Management with COPRA® RollScanner

- | Digitizes and catalogs existing rolls
- | Separate user terminal with optional touch operation
- | Fully automatic scanning without first programming
- | Seamless integration into COPRA® RF
- | Interface with other CAD programs
- | Analysis and revision of existing roll sets
- | Interface with COPRA® Roll Management (lower cost by using „scrapped“ rolls)
- | Timely detection of roll wear and tear

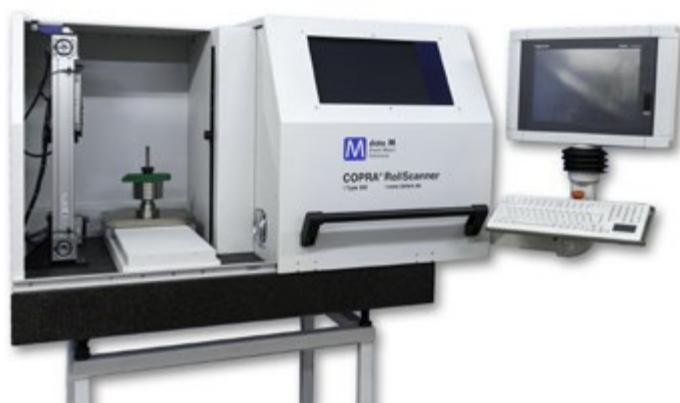

COPRA® RollScanner Type 300

## data M – Your Partner in Implementing CNC Roll Forming Machines

data M integrated solutions for CNC roll forming plant are unique throughout industry.

### 3D Profiles

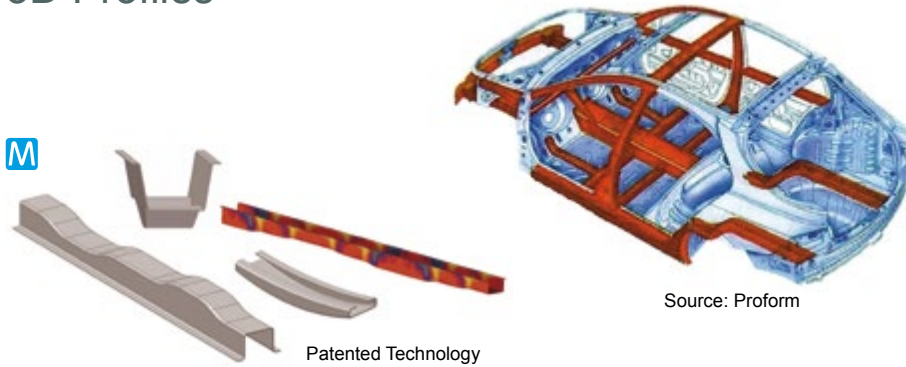

data M partners and supports industrial implementation:

- | Tool design
- | Forming simulation
- | Machine building
- | Programming of machine controllers
- | Feasibility studies
- | Measurement and verification of specifications and tolerances
- | Process configuration and optimization
- | Plant engineering solutions

data M is a member of the German Engineering Association:

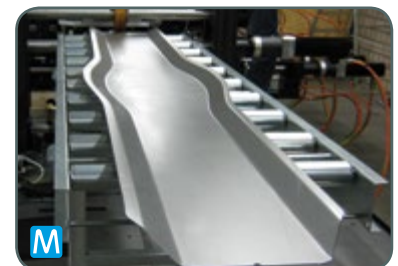
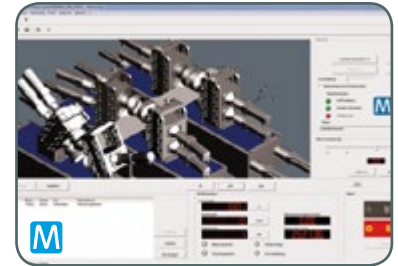
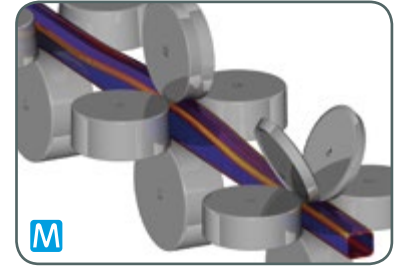



# COPRA® RF and COPRA® FEA RF

data M uses COPRA® RF to provide its services and conduct research projects – constantly optimizing it for roll forming applications.

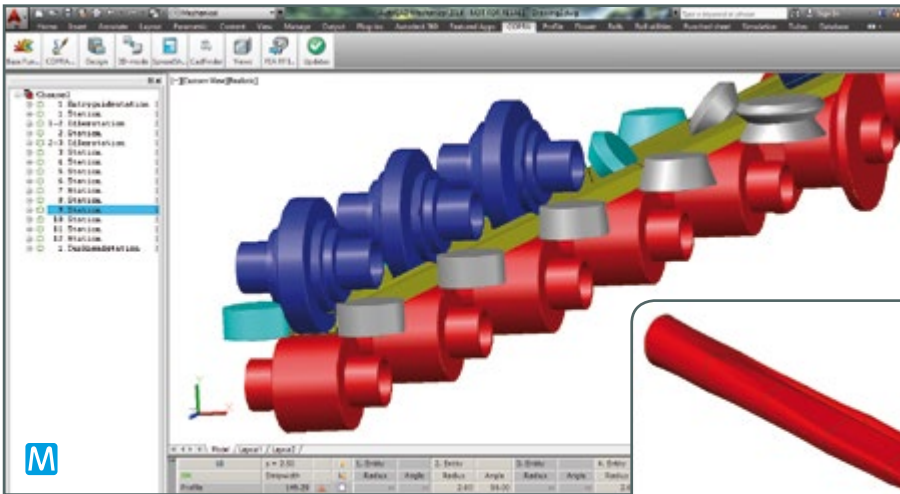

COPRA® RF



COPRA® RF WireRolling

COPRA® RF leads the market in design software for roll forming. It is still being further developed and perfected after 25 years.

Not only major enterprises can invest in COPRA®. This modular software is affordable and adaptable, offering startup solutions for SME business too.

# COPRA® - The Standard in Roll Forming Industry

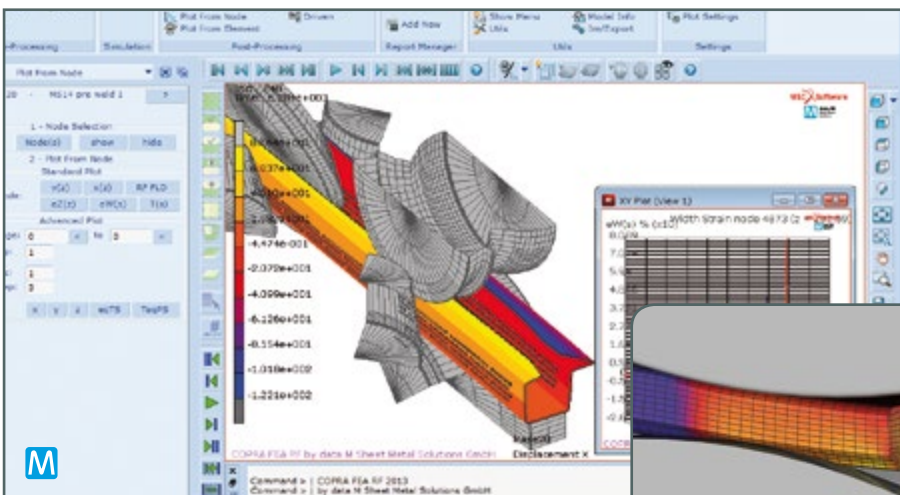

COPRA® FEA RF

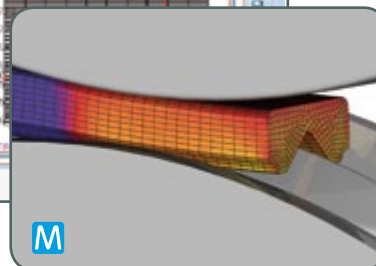

COPRA® FEA RF WireRolling

data M has experience in FEA simulation going back 20 years. More than 20 roll forming specialists (virtually half the workforce) are engaged in developing COPRA® FEA RF. The software is optimized for roll forming – the user needs no expertise in FEA to understand procedures and results.

## Research & Development – Things that Count Big at data M

Since the company was established nearly 30 years ago, data M has played an active role in research projects. All the experience gained is invested in continuing product development and enhancement.

Some examples of recent projects:

### RF Expert:

„Improved cold roll forming of sheet metal by numerical simulation, process monitoring, and artificial vision.“



### PROFORM:

„An innovative manufacture process concept for a flexible and cost effective production of the vehicle body in white: Profile Forming.“

EU-funded project involving 22 European partners (eg Fiat and Daimler).



In the course of its R&D activities data M has cooperated for many years now as a project owner or project member with prominent partners all over the world including:

PtU Darmstadt, Deakin University Australia, IFUM University Hannover, KUAS University Taiwan, Dalarna University Sweden, NCUT China, Ohio State University USA, IUL TU Dortmund, Mondragon University Spain, LFT University Erlangen, TU Munich, Fraunhofer Institute IWU Chemnitz, LZH Hannover.

data M is a member of the following associations:



Recipient of the 2012 EFB quality award

FOSTA R&D project:

Albert Sedlmaier, managing director of data M, based on research in 1984 as part of a FOSTA project at Munich Technical University on the subject of „Knowledge-based Design of Roll Forming Tools – CAD/CAM Applications“, founded the data M company in 1987.



**data M**  
Sheet Metal  
Solutions

**data M Sheet Metal Solutions GmbH**

Am Marschallfeld 17 | 83626 Valley, Germany

Tel.: +49(0)8024-640-0

datam@datam.de | www.data-m.com